



Airbrush

MODEL NUMBER: BD-105

USER GUIDE

After Sales Support

UK/N.IRELAND HELPLINE N°: 01270 508530
WEBSITE: www.airbrushheaven.co.uk
EMAIL: enquiries@airbrushheaven.co.uk



Contents

1. Welcome Section
2. General Information & Safety Instructions
3. Contents & Features
4. Parts & Assembly
5. General Maintenance
6. Using the Airbrush
7. Specifications
7. Trouble Shooting

After Sales Support

UK/N.IRELAND HELPLINE N^o: 01270 508530

WEBSITE: www.airbrushheaven.co.uk

EMAIL: enquiries@airbrushheaven.co.uk

Welcome

Congratulations!

You have made an excellent choice with the purchase of this quality AIRBRUSH HEAVEN product.

By doing so you now have the assurance and peace of mind which comes from purchasing a product that has been manufactured to the highest standards of performance and safety, supported by the high quality standards of Airbrush Heaven.

We want you to be completely satisfied with your purchase so this AIRBRUSH HEAVEN product is backed by a comprehensive manufacturer's 1 year warranty and outstanding after sales service through our helpline.

We hope you enjoy using this product for many years to come.

If you require technical support or in the unlikely event that your purchase is faulty, please telephone our helpline for immediate assistance. Faulty product claims made within the 1 year warranty period will be repaired or replaced free of charge provided that you have a satisfactory proof of purchase (keep your receipt/invoice safe). This does not affect your statutory rights. However be aware that the warranty will become null and void if the product is found to have been deliberately damaged, misused and/or disassembled other than directed. See warranty certificate for full details at the back of this guide.

General Information & Safety Instructions

- Industrial applications must follow OSHA requirements.
- Maintain a safe working environment. Keep the work area well lit and make sure there is adequate work space.
- Use the product only in a well ventilated area.
- Check for damaged parts including hoses before using this product. Carefully check that it will operate properly and perform its intended function. Replace or repair damaged or worn parts immediately.
- Always read and adhere to all safety warnings and instructions provided in the directions of the medium being used.
- Wear ANSI approved safety impact eye goggles and an ANSI approved dust mask or respirator when using this product.
- Do not exceed the maximum pressure rating of 50 PSI.
- Adult supervision is advised when children are using this product.
- The airbrush is designed only to spray non-flammable medium. Never spray petrol, paraffin, or any flammable liquids.

WARNING! *The warnings, precautions, and instructions discussed in this manual cannot cover all possible conditions and situations that may occur. The operator must understand that common sense and caution are factors, which cannot be built into this product.*

After Sales Support

UK/N.IRELAND HELPLINE N°: 01270 508530

WEBSITE: www.airbrushheaven.co.uk

EMAIL: enquiries@airbrushheaven.co.uk

Contents & Features



Contents

- 1 x Single Action Airbrush
- 1 x 20cc Plastic Reservoir Jar
- 1 x Aircan Regulator
- 1 x Vinyl spiral air hose
- 1 x 1/4" BSP to 0.5mm adaptor
- 1 x Fitted Protective Case

Features

- Pistol grip action trigger
- 0.3mm Fluid nozzle
- Adjustable needle
- Works with both a compressor and canned air

After Sales Support

UK/N.IRELAND HELPLINE N°: 01270 508530
WEBSITE: www.airbrushheaven.co.uk
EMAIL: enquiries@airbrushheaven.co.uk

Parts & Assembly

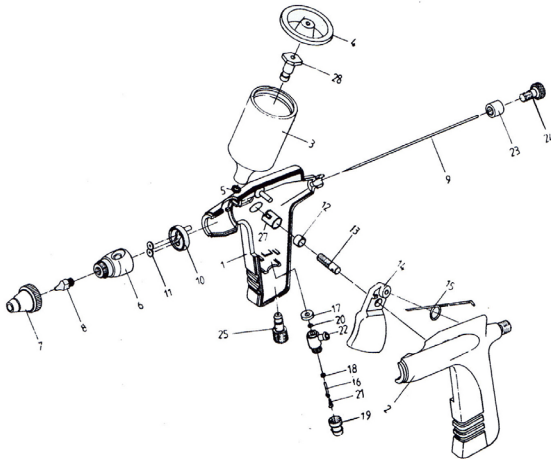

1. Housing R
2. Housing L
3. 22cc Plastic Reservoir
4. Cap
5. O-Ring
6. Nozzle Seat
7. Fluid Cap
8. Nozzle
9. Needle
10. Nozzle Seat Cap
11. O-Ring
12. Bushing
13. Adjustment Screw
14. Trigger
15. Trigger Spring
16. Plunger
17. Valve Upper End Cap
18. O-Ring
19. Valve Lower End Cap
20. O-Ring
21. Plunger Spring
22. Valve Housing
23. End Cap
24. Fluid Adjustment Screw
25. Inlet
26. Hose Assembly
27. Adjustment Screw
28. Fluid Inlet Screw
29. Air Regulator Valve
30. Air Hose Adaptor

After Sales Support

UK/N.IRELAND HELPLINE N^o: 01270 508530

WEBSITE: www.airbrushheaven.co.uk

EMAIL: enquiries@airbrushheaven.co.uk

General Maintenance

Storage

- Always disconnect the airbrush from its air supply source before any maintenance on the airbrush body.
- When not in use, tools and equipment should be kept in a dry location to inhibit rust.

Attaching the Aircan Regulator

- Attach the hose to the regulator.
- Attach the regulator to the top of the aircan and turn to tighten.
- Attach the other end of the hose to the airbrush.
- Twist the top valve clockwise to release air.
- Use the top valve to regulate pressure.
- Twist the top valve anti-clockwise to turn off the air.

Please Note:

For prolonged spraying please use a compressor. We recommend our, AS-18A or AS-186 compressor for this model.

Basic Cleaning

- Empty the reservoir jar of used medium.
- Remove and wipe clean the reservoir jar.
- Reattach the clean reservoir jar and fill with the appropriate cleaning solution.
- Spray the cleaner through the airbrush until it sprays clear.
- Re-connect to the airline & spray until dry.

Please Note:

Spray into a cleaning jar or filter of some kind. This keeps overspray out of the air and you. We recommend the Clean Pot available from our website.

For full cleaning advice and video demonstrations please visit:
www.airbrushheaven.co.uk

After Sales Support

UK/N.IRELAND HELPLINE N°: 01270 508530
WEBSITE: www.airbrushheaven.co.uk
EMAIL: enquiries@airbrushheaven.co.uk

Using the Airbrush

Setting up & using the Airbrush

- Attach the hose to the compressor or aircan.
(We recommend our AS-18A or AS-186 compressor for this model)
- Set air pressure to 2-40 PSI on the compressor.
- Remove the protection cap from the airbrush.
- Add your chosen medium to the reservoir cup.
- Press down on the trigger to allow air to flow through the brush.
- Pull the trigger backwards to start spraying.

You can vary the amount of medium flow by tightening or loosening the adjusting screw at the rear of the airbrush.

Always test spray before starting your main project.

Mixing & Thining Medium

Generally, the most common medium used in conjunction with an airbrush is paint. It is highly recommended that you dilute your medium down to the same consistency as semi skimmed milk.

Read the directions on the container to see if thinners or water should be used to dilute the medium to the correct consistency.

When mixing medium, it's highly recommended you use the same brand and type for best results.

Please Note:

Use the correct solvent for thinning: Use lacquer thinner for all lacquer medium, paint thinner for all oil based medium, enamel thinners for all enamel based medium, acrylic thinners for acrylic and clean water for water based medium.

Always read the label of your selected medium.

After Sales Support

UK/N.IRELAND HELPLINE N°: 01270 508530

WEBSITE: www.airbrushheaven.co.uk

EMAIL: enquiries@airbrushheaven.co.uk

Specifications

- Double action trigger
- 20cc Plastic reservoir cup
- Aircan Adaptor
- 0.30mm Fluid nozzle
- 50 Psi maximum
- 1/4" BSP to 5mm adaptor

Trouble Shooting

PROBLEM	CAUSE	SOLUTION
Medium leaking.	Head of needle bent or distorted. Nozzle and needle not fully contacted.	Repair or replace parts. Loosen screw, make sure nozzle and needle fully contacted and then screw tightly.
Poor medium atomization.	Airbrush nozzle is partially blocked. Needle screw loose.	Wash nozzle with relevant cleaner. Make sure screw is tight.
Air bubble(s) in the cup.	Faulty nozzle seal ring causes air blowback.	Replace nozzle seal ring.
Medium leaks from back.	The gap between needle and its seal is enlarged.	Take off parts on the back, fasten screw or replace the seal.
Air leaking	Valve lever stuck	Take trigger off; apply lube after cleaning and put trigger back.
Medium spatter.	Bent needle tip.	Replace needle.

After Sales Support

UK/N.IRELAND HELPLINE N°: 01270 508530
 WEBSITE: www.airbrushheaven.co.uk
 EMAIL: enquiries@airbrushheaven.co.uk



Warranty Certificate

Warranty

This product is guaranteed to be free from defects in workmanship and parts for a period of 12 months from the date of purchase. Defects that occur within this warranty period, under normal use and care, will be repaired, replaced or refunded at our discretion, solely at our option with no charge for parts and labour. The benefits conferred by this warranty are in addition to all rights and remedies in respect of the product the consumer has under existing U.K. laws.

Proof of Purchase

This warranty is valid for the original purchase and is not transferable. Please keep your purchase receipt as proof of purchase and as proof of the date of when the purchase was made. The receipt/invoice must be presented with the warranty card when making a claim under this warranty.

Service during the Warranty Period

Please ensure the product is properly packaged so as to ensure that no damage occurs in transit. Also make sure that you have included a detailed explanation of the problem.

Extent of the Warranty

This warranty is limited to defects in workmanship or parts. All defective products or parts will be repaired or replaced. This warranty does not extend to accessories.

Normal Wear and Tear

This warranty does not cover normal wear and tear of the product or parts.

Exclusions

This warranty does not cover the following:

- Any defect caused by accident, misuse, abuse, improper installation or operation, lack of reasonable care, unauthorised modification, loss of parts, tampering or attempted repair by a person not authorised by the distributor.
- Any product that has been damaged by lightning strike either directly or indirectly, or on a main's or vehicle outlet power surge or liquid ingress.
- Any product that has not been installed, operated or maintained in accordance with the manufacturer's operating instructions provided with the product.
- Any product that has been used for purposes other than domestic use.
- The product if it is located outside of the U.K., N. Ireland or Republic of Ireland
- Any damage caused by improper power input or improper cable connection.

After Sales Support

UK/N.IRELAND HELPLINE N°: 01270 508530
WEBSITE: www.airbrushheaven.co.uk
EMAIL: enquiries@airbrushheaven.co.uk





Warranty Card

Airbrush

Model Number: BD-105

Please keep your purchase receipt/invoice together with your warranty card

Name: _____

Address: _____

 _____

Date of purchase: _____

Location of purchase: _____

Fault Description:

We recommend that you attach a photocopy of your receipt/invoice, showing the date of purchase, to this warranty card and keep it for your reference. In the event of a product fault, please call the After Sales Support team. Please ensure that you have the product details (as shown on this card) to hand so that the support team are able to respond as quickly and efficiently as possible.

After Sales Support

UK/N.IRELAND HELPLINE N°: 01270 508530
WEBSITE: www.airbrushheaven.co.uk
EMAIL: enquiries@airbrushheaven.co.uk

Service Helpline

AIRBRUSH HEAVEN
1 SOLWAY COURT,
CREWE BUSINESS PARK,
CW1 6LD



For further help, advice and video demonstrations please visit:
www.airbrushheaven.co.uk